



**SAFETY  
BUILT ON  
A SOLID  
FOUNDATION.**





## DRIVEN TO RESPOND.

### Every response rides on a foundation of strength.

Responses are challenging. Much is at stake. Trucks are traveling fast, making tight turns, loaded with heavy equipment and carrying the department's most valuable asset: the crew. With so much riding on every response, make sure it sits on a premier foundation. Spartan Emergency Response has been a driving force in the manufacturing of custom cab chassis since 1975. Many factors go into a successful apparatus. With Spartan, you know you'll start building that success from the road up.

Our chassis begin with a strong foundation, using custom production methods and materials that build the most highly engineered frame in the industry. And while our chassis can handle heavy-duty applications, it can also maneuver swiftly, with the tightest turn radius on the market. Our cabs are built to keep the crews comfortable and safe with high rooflines, flat floors, Advanced Climate Control systems, and the industry's first Advanced Protection System.

**IT'S A FORTRESS  
ON WHEELS.**



*Galvanized steel frame rails shown with optional powder coating and painted frame.*



## Spartan Advanced Protection System®

If the crew doesn't arrive on the scene safely, even more lives hang in the balance. At Spartan, we face reality head on with cabs that feature the most advanced safety provisions available in the market today.

The Spartan Advanced Protection System® (APS) is the #1 safety system in the industry. Designed and purpose-built for firefighters, it combines forward-thinking apparatus safety, developed around the needs of the first responder. This market-leading system includes:

- Eight airbag positions, the most offered by any manufacturer — including knee airbags and the only side impact curtain airbags in the industry — which give your apparatus the highest available impact and anti-ejection protection available.
- Innovative seat belt systems and outboard sensors that enable an intelligent restraint control, dramatically reducing restraint system injuries.
- Ergonomic driver controls that help ensure safe and easy operation of the vehicle.
- Higher rooflines, added hip room and a cab-forward engine tunnel that provide more space and comfort for the driver, officer, and crew.
- Optional 360° camera to improve sightlines all around the apparatus.
- Third-party testing to ensure cab safety from every perspective. We test for roof crush, front impact, roll stability control, airbags, seat mounting and seat belt restraint system validation.
- Blind Spot Detection monitors provide a visual warning when other vehicles are located in the driver and officer side and rear blind spots, helping to prevent accidents to and from a call.

## Safe and Spacious Cabs.

Designed with firefighters in mind by offering the most spacious and ergonomic cabs in the industry.

Flat floors, low step heights, and taller, wider cab doors allow firefighters to get in and out quickly at the scene. The Spartan raised roof extends over the driver and officer, making it easier to maneuver within the cab. We've even optimized the engine tunnel to increase leg and hip room for the front seats, while giving more floor space to the rear crew. Our cabs can comfortably seat up to 10 crew members.

Designed to be quieter and more comfortable, we've maximized every square inch of our cabs without increasing the 99" width.

Side Impact Curtain Airbags



Knee Airbags

## IT'S A FORTRESS ON WHEELS.

### 35,000 GAWR-Rear Axle

With a 35,000 pound GAWR-Rear Axle, Spartan offers the strongest rear axle used in fire service — stout enough to safely support and transport heavier aerials and pumpers.

### Remarkable Strength

Cross-members are gusseted and mounted with grade eight flanged fasteners. Finite Element Analysis (FEA) validates the strength and performance by monitoring stress points for material efficiency, and strain gauge analysis testing verifies the structural integrity and compliance with NFPA design standards. Limited Lifetime warranty\* on all frame-rails and cross-members.



### Tightest Turn Radius

The tightest turn radius and the most maneuverable chassis on the market. The turning radius cramp angles range up to 53° with Independent Front Suspension and offer up to a 19-degree approach angle, exceeding NFPA 1901 standards.

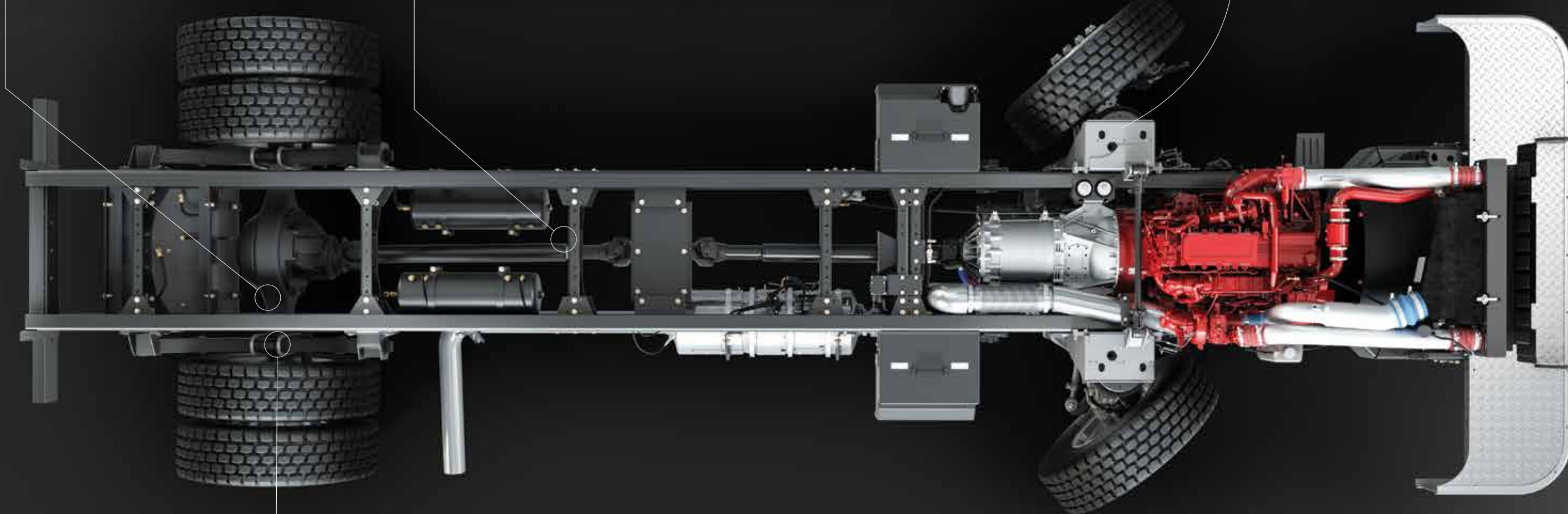

### Exceptional Weight Capacity

The weight capacity to withstand heavy-duty applications such as aerials and tankers.

### A Strong, Long-lasting Foundation

Our galvanized steel chassis frame rails provide strength and integrity while resisting rust and corrosion. They are built to last with low maintenance costs—holding up to the rigors and punishment dished out by hard-working fire departments.

### Optional Full Air Ride Suspension

Spartan's optional full air ride suspension increases the comfort and quality of the ride — cushioning the crew and equipment and improving ride and handling.

## Clean Cab.

Simply put, your people are covered with potentially carcinogenic substances after fighting a fire. Cleaning gear and placing it outside the cab is both logical and life-saving. And it's the simple foundation of our Clean Cab. With this revolutionary cab design all tools and contaminated equipment can be stored outside the cab interior.

### Advanced Filtration System

Spartan's Advanced Filtration System (AFS) features a high-efficiency particulate air (HEPA) filter, which can trap or filter out almost 100% (99.97%) of toxic particles and contaminants that are airborne in the cab. The filter can be placed in several areas within the cab to not impede cab space.

### Easy-clean interior

Our easy-to-clean liner covers the interior surfaces with a seamless material impervious to gases and liquids. Contaminants brought into the cab from boots or shed from PPE can easily be cleaned once the apparatus is back in the station. Gaps in materials where contaminants could hide are eliminated.

### Optional SCBA containment

Spartan's Clean Cab includes options for outside compartments to store the SCBA tanks and packs that is easily accessed but still shielded from the cab interior.

Compartment racking systems can be customized to meet specific department needs through your OEM or dealer.

### Floors

Treadplates can be covered with an easy-to-clean bed-liner with no stair nosing to catch debris and rolled edges for easy cleaning.

### Easy-clean seating

Spartan partnered with H.O. Bostrom to provide minimally seamed, zip-off seat covers with a foam block encapsulated barrier that reduces gas and liquid absorption. The seat covers are removable and replaceable for deeper cleaning to remove any toxins that transfer from firefighters or their gear.

### Clean. Remove. Isolate.

Spartan's Clean Cab makes cabs easier to clean, filter out airborne particles, and provide exterior storage compartments to isolate contaminated gear after a call.

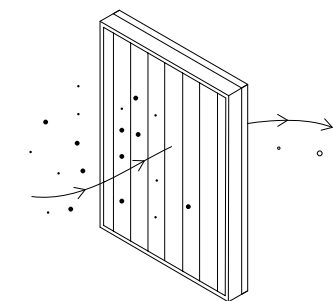

Spartan's AFS filters out 99.97% of toxic particles and contaminants (MERV 17 filtration rating), equal to or better than most hospital operating rooms. Most competitors only filter out 15%.



\*See the Spartan chassis-specific Limited Warranty statement for complete details regarding warranty coverage, disclaimers, remedies and exclusions.



## High Air Intake System.

Communities at risk of severe weather and flooding need emergency service and equipment that can weather the storm. An apparatus with low air intake can be easily damaged and disabled if water enters the engine—stopping a response vehicle in its tracks. And causing high repair costs on high-value equipment.

Spartan mitigates the risk with our new High Air Intake design, a standard offering on all our models and engine sizes.

Spartan's High Air Intake has fewer connections and places the air filter and ember separator above the radiator and turbo connection.

Placing the air intake behind the cab grille provides a higher location to help prevent potential damage from water admission.

Air filter replacement can be easily done without tools and without compromising the clean side of the intake system.

## Advanced Climate Control.

Spartan's well-designed cabs also offer the industry's best HVAC system—creating a safer and more comfortable environment for firefighters working in any kind of climate.

Enduring over 20,000 miles of performance and durability testing, Spartan's Advanced Climate Control System exceeds standard performance requirements and maintains a comfortable cab, no matter the condition. It's innovative design helps cool and heat the cab interior aggressively while distributing air volume evenly to all occupants. It also quickly and effectively evacuates condensation, defrosts/defogs and clears flash fogging. All to keep firefighters comfortable and safe to and from every response.



### - 40° in 30 Minutes

Spartan's Advanced Climate Control System reduces interior cabin air temperature from 122° F (+/- 3° F) to 80° F in 30 minutes.\*



### + 232% Air Velocity

Air velocity has been improved an average of 232 percent which distributes AC or heat throughout the cab and to all occupants more evenly and quickly than traditional roof-mounted HVAC systems.



### 0 Condensation

In testing, with AC on MAX for 1 hour with the doors open at 90° F and 95 percent relative humidity, all condensate generated by the system had been drained outside of the vehicle.



### +80° in 30 Minutes

With the cabin air temp at 0° F, the foot area average air temperature reaches 80° F within 30 minutes.



### 30-Second Defogging

When in defog mode, the system clears the windshield and the front side glass of any flash fogging in 30 seconds or less. The normal defrost mode pushes air to the windshield and side glass and defrosts in a matter of minutes, even in a fully frosted condition.

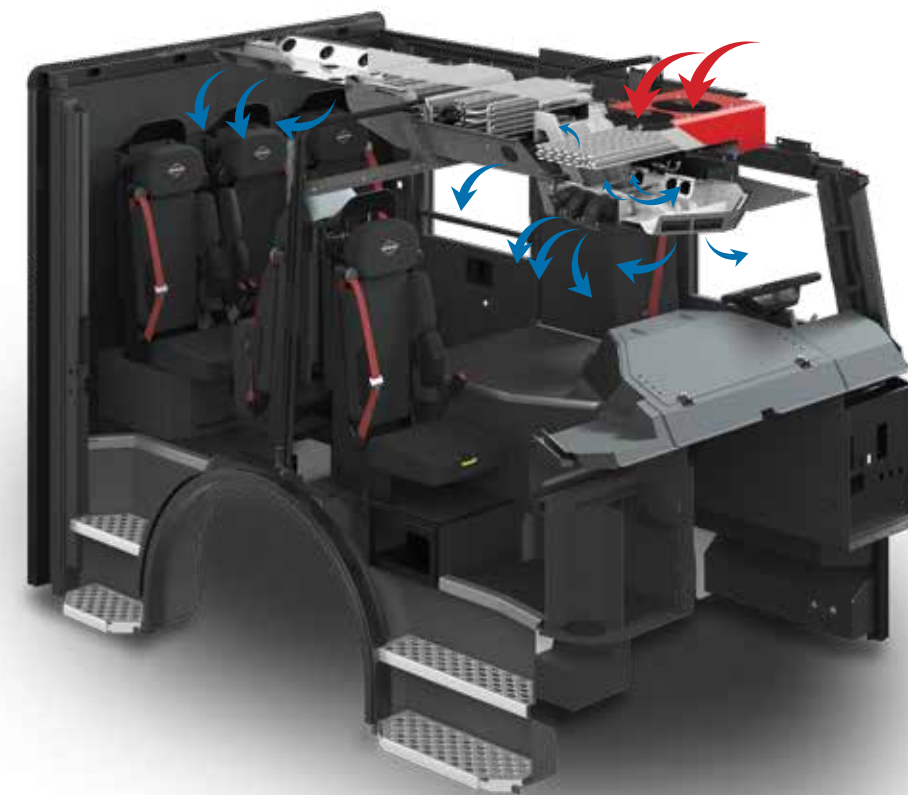

## Roof & Seating Options.

Spartan offers flat, 5", 10", 20", and 24" raised roof options as well as multiple seating configurations to provide your crew with extended legroom, improved visibility, and additional storage.

### Seating Configurations (Available in 99" and 94" cab widths)

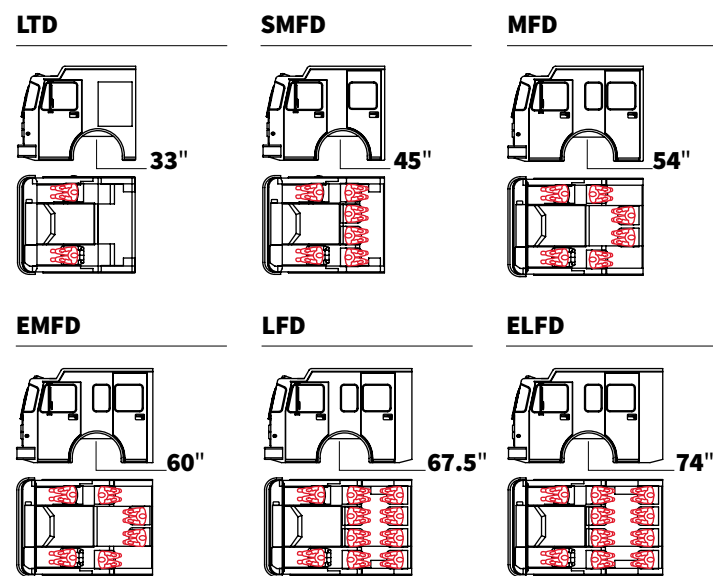

### Roof Height Options

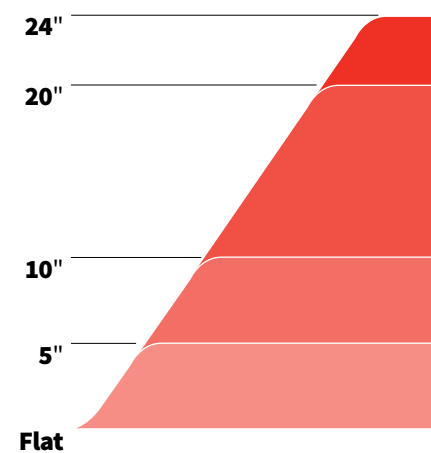

## Cab Construction

Reinforced Roof Structure  
C-Channel Roof Support  
Triple Reinforced Box Front Bulkhead

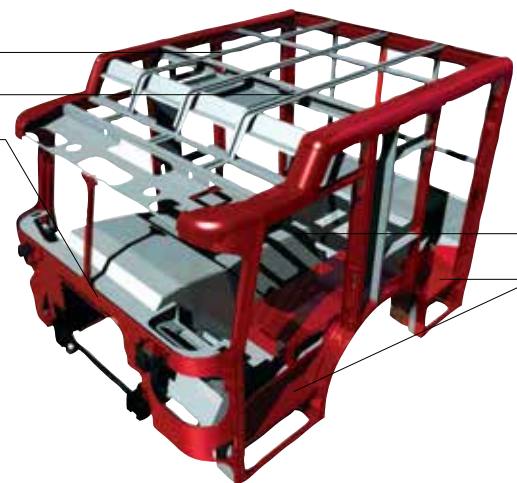

Reinforced Engine Compartment  
Reinforced Front & Rear Step Assemblies

## Independent Front Suspension.

Spartan's emergency response cab and chassis have a heightened level of control and maneuverability due to an air ride independent front suspension. Our system is ideal for carrying the heaviest of loads and help reduce steering effort while maneuvering safely through crowded intersections and tight corners.

### Specs

<b>Cramp Angle</b>	Maximum: 53° with 18,000-20,000 lb. front axle weight rating Maximum: 48° with 24,000 lb. front axle weight rating
<b>Suspension Type</b>	Air ride suspension with the ability to raise and lower the height of the chassis.
<b>Stability</b>	Air ride suspension allows the ability to automatically level the vehicle from side to side.
<b>Weight</b>	Light weight, yet durable and allows for more capacity inside the cab for equipment.
<b>Tires</b>	Spartan's IFS allows for a wide range of tire sizes and capabilities.
<b>Safety &amp; Handling</b>	Spartan's engine and transmission module is positioned evenly over the IFS which provides: <ul style="list-style-type: none"> <li>• A lower center of gravity</li> <li>• Engine forward of driver to protect occupants</li> <li>• More crew area in a shorter cab</li> </ul>
<b>Ride Quality</b>	Provides a smoother and more controlled ride than a traditional standard I-beam axle.





## More Ways to Make the Right Choice.

Offering a range of 4x2, 4x4, and 6x4 configurations, horsepower options, wheelbase dimensions, and weight capacities to meet the specific needs of your station's environment — whether it's urban with tight roads, suburban or rural, off-road. We've got the right chassis to fit any department's needs.



### Gladiator®

Available in LTD, SMFD, MFD, EMFD, LFD, and ELFD cab styles.

- 99" wide aluminum cab
- 400-600 hp
- Seats up to 10
- IFS or Spring Front Suspension
- 42° - 53° Cramp Angle
- 270 - 430 Amp Alternator
- 136" - 303.5" Wheelbase



### Metro Star®

Available in LTD, SMFD, MFD, EMFD, LFD, and ELFD cab styles.

- 94" wide aluminum cab
- 380-500 hp
- Seats up to 10
- IFS or Spring Front Suspension
- 42° - 53° Cramp Angle
- 270 - 360 Amp Alternator
- 136" - 303.5" Wheelbase



### Metro Star RT®

Designed for Ambulances and Rescue Transport Vehicles. Available in LTD, SMFD & MFD cab styles.

- 94" wide aluminum cab
- 380-450 hp
- Seating up to 6
- Lighter axles ratings with annealing rear air suspension
- 50° Cramp Angle
- 270-360 Amp Alternator
- Several wheel base options

## Best-in-class Paint Finish.

Spartan's state-of-the-art equipment and process results in the highest quality paint finish in the industry. We offer over thousands of paint colors to meet the specific interior, exterior, under cab, and frame color needs any department may desire.

## Best-in-class Production.

Our state-of-the-art custom assembly features the latest technology to deliver the greatest cab and chassis integrity. Our double and triple wall construction and aircraft-style cab extrusions limit weight while adding strength, safety, and longevity.



